



BoonDocker Nitrous System Universal Dirtbike Installation Instructions

Before you begin, please read the instructions below and check kit contents

Nitrous Kit Contents:

- | | |
|---|---|
| 1 – Nitrous Manifold with fittings installed | 1 – 1/8" NPT to 4AN adapter for solenoid |
| 1 – Nitrous Bottle | 1 – pushbutton switch |
| 1 – 4AN fitting for bottle | 1 – mounting clamp for pushbutton switch |
| 1 – 1/8" plug for bottle | 1 – 9.6V Nicad battery with charger (for non-lighting coil models) |
| 1 – bottle bracket | 1 – quick connect electrical connector for battery (for non-lighting coil models) |
| 1 – high pressure braided hose | 5 – orificed cup plugs (4-3/16", 1-1/8") |
| 1 – 18" length of 1/8" black nylon hose | 1 – 12" length of 3/16" vent tubing |
| 1 – solenoid | 1 – 3/16" x 3/16" x 3/16" barbed Tee |
| 1 – solenoid holding bracket | |
| 1 – 1/8" NPT compression fitting for solenoid | |

Tools Required:

- Drill + bits (3/4", 1/4")
- Wire stripper / crimper tool
- Sidecutters
- 5/32" and 7/32" allen wrench
- Basic wrench and socket set
- Flatblade screwdriver
- Teflon Tape

Theory of Operation:

A common misconception about nitrous oxide is that it is explosive or flammable. Nitrous by itself does not burn, nor is it explosive. At 565 deg. F, nitrous oxide (N₂O) breaks apart and forms two parts nitrogen and one part oxygen. Inside an engine, this added oxygen speeds up the combustion process (the nitrogen plays an important part in buffering the reaction). Whenever nitrous is used, additional fuel is necessary, otherwise the added oxygen will act as a blow-torch inside your engine. When used properly, nitrous oxide provides the same benefits as turbocharging or supercharging your engine (extra power is made by burning more fuel and oxygen), but without the added cost or complexities.

Below is a diagram of the major components of the BoonDocker Liquid Nitrous System. The simplicity of this system makes it the most reliable, easy to tune, and easy to install nitrous system available. By using the existing fuel system (carburetor) to add the required extra fuel for nitrous, the complexity and unreliability of extra components is eliminated.

The part that makes the BoonDocker nitrous system so unique is our patent pending Nitrous Manifold. This manifold simply mounts on the airbox or airfilter where it sprays a fine mist of nitrous that is then drawn into the engine through the carburetor(s). This allows the nitrous to be naturally aspirated into the cylinder instead of being forced, which is much friendlier to the motor and allows the nitrous to be used in a much wider range of throttle and rpm settings.

This nitrous manifold greatly simplifies the way extra fuel is delivered that is needed for nitrous use. The carburetor vents are connected to this manifold, allowing the carburetor(s) to breathe normally through the airbox when nitrous is not used. When nitrous is sprayed, the manifold produces a positive pressure that goes to the carburetor float bowl, which "pushes" more fuel through the main jet of the carburetor(s). This eliminates the need for an extra fuel pump, fuel solenoid, extra plumbing, and nozzle(s) that are necessary to inject the extra fuel in other systems.

(continued on next page)

This manifold is also designed to vary the float bowl pressure in relation to nitrous pressure, thus keeping the nitrous and fuel delivery in sync. Fluctuations in bottle temperature greatly affect nitrous pressure, which affects nitrous delivery. By automatically adjusting the fuel delivery as nitrous pressure varies, this manifold makes nitrous safe, reliable, and easy to use.

Be sure to understand and follow the tuning instructions at the end of these instructions. Proper tuning is an important part of any performance-enhancing product.

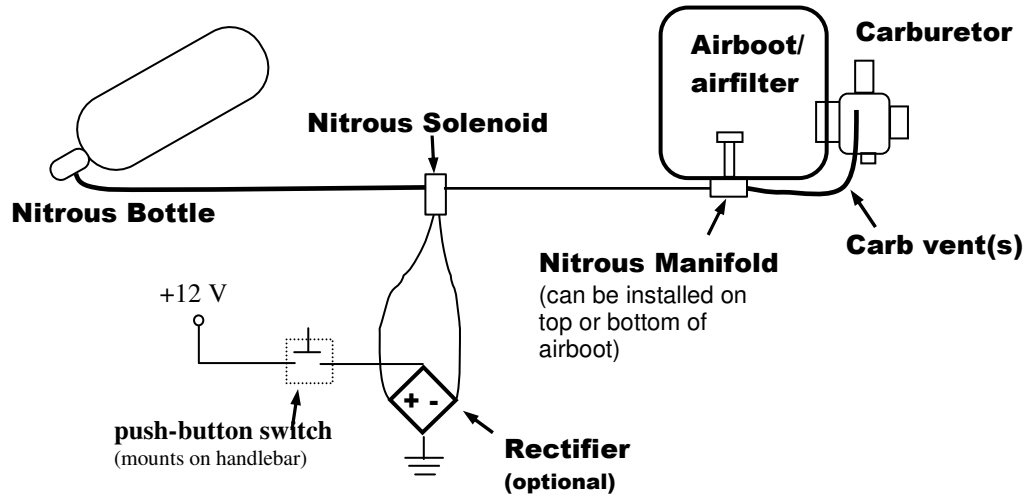

Part I – Bottle Installation

A. Bottle Valve Fittings

Insert the 4AN x 1/8" NPT fitting and the 1/8" NPT Plug into the bottle valve (these are attached to the lid of the box for the bottle). Use Teflon tape to seal the threads – be sure not to get tape inside the threads!

B. Bottle Mounting Position

With nitrous in the bottle, both nitrous liquid and nitrous gas are present under high pressure (760psi at 70 deg F). Due to gravity and acceleration forces, the liquid portion of the nitrous will be at the bottom and rearward parts of the bottle. For this nitrous system to work properly, it is important that nitrous liquid be drawn from the bottle. Nitrous vapor will cause a significant decrease in performance.

For best results, the bottle should be mounted so the valve is pointed down and towards the back of the vehicle as shown below.

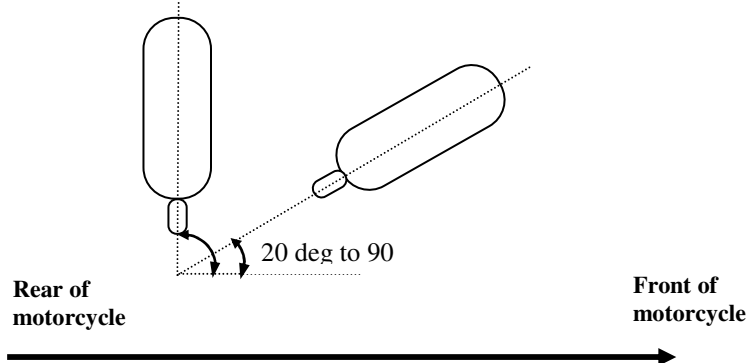
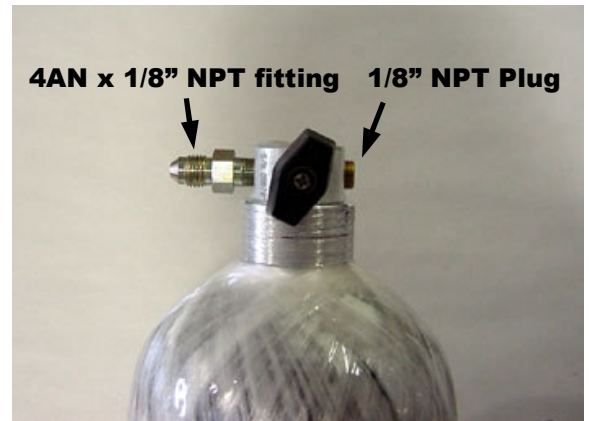

Bottle mounted inside airbox:

For some applications, a small bottle can be mounted inside the airbox as shown. Note: because of the restricted space, it was necessary to mount this bottle at a non-optimal angle (the valve is pointed towards the front instead of the rear).



Bottle mounted on front forks:

A bracket can be made to install the bottle on the front forks as shown.



Bottle mounted on handlebars:

The bottle can be mounted across the handlebars as shown. Important note: In this position the bottle must contain a siphon tube!



C. Bottle Filling /Weights

Automotive speed shops that sell nitrous kits can usually refill nitrous bottles. This bottle can be filled with non-medical grade nitrous oxide that contains a very small amount of sulfur dioxide (combines with water in your lungs and forms sulfuric acid if breathed too much). This is the same nitrous that is used for all nitrous oxide systems, usually with the name Nytrous-Plus.

Fill the bottle according to the weights below. We do not recommend overfilling the bottle – when the bottle gets hot, it will rupture the blow-off disk.

<i>note: all weights are in fractions of pounds, not ounces</i>	Bottle Size							
	4.0lb CF	2.9lb CF	3.0lb AL	2.5lb AL	20oz AL	16oz AL	12oz AL	9oz AL
Weight of Cylinder & Gas	7.4 lb	6.0 lb	6.1 lb	6.1 lb	3.0 lb	2.8 lb	2.1 lb	1.7 lb
Weight of Cylinder Empty	3.4 lb	3.1 lb	3.1 lb	3.6 lb	1.7 lb	1.8 lb	1.3 lb	1.1 lb
Weight of Gas	4.0 lb	2.9 lb	3.0 lb	2.5 lb	1.3 lb	1.0 lb	0.8 lb	0.6 lb

Part II – Nitrous Manifold Installation

1. Locate a suitable place on the airboot between the airfilter and the carburetor for the nitrous manifold. Be sure there is adequate room for the 2.5” stem to fit inside. For best results the manifold should spray into the airflow that goes directly to the carburetor(s). Nitrous should not be sprayed through the filter.
2. Using the template below as a guide, drill the holes shown.
3. Separate the stem from the nitrous manifold by unscrewing the allen head bolt in the back.
4. Install the manifold to the airboot with the stem half inside and the aluminum half on the outside so the airboot is sandwiched in between. Align the two halves together then thread the bolt in so the two halves are tight against the airboot. Use silicone to seal any airleaks.

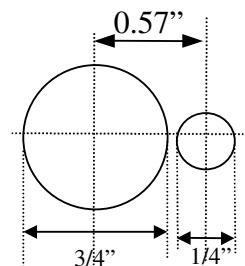

Manifold Cutout Template

Part III – Solenoid / Hose Installation

1. Before installing the following fittings, apply a thread sealant or teflon tape to the threads – be careful not to contaminate the insides of these fittings.
 - a. Connect the Nitrous Filter to the side of the solenoid marked “IN”.
 - b. Connect the brass compression fitting to the side of the solenoid marked “OUT”.
2. Locate the solenoid in or near the airbox as shown in the picture. Use the padded strap to secure the solenoid. The 1/8” black nylon hose going to the manifold and the high pressure hose from the bottle needs to easily reach the solenoid with no sharp bends.
3. Connect the 1/8” black nylon line from the solenoid brass fitting to the brass fitting on the nitrous manifold. Keep this away from hot items. Note – do not overtighten the compression fittings!
4. Connect the high-pressure braided hose from the bottle to the solenoid. If a universal hose end is included, see the directions below.

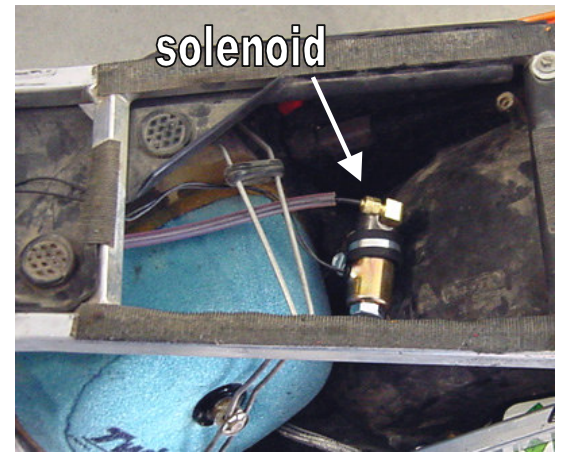
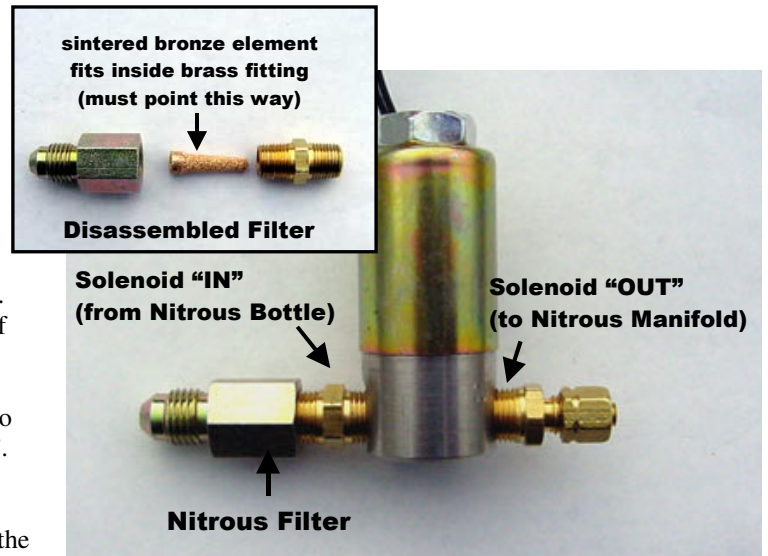

Universal Hose End Installation

Some kits come with a hose with one end crimped on and a universal end that is not installed. This allows the hose to be cut to length (a hacksaw can be used). Install the end as follows.

1. Cut hose to length.
2. Clean the hose using compressed air. Make sure there is no debris left inside the hose.
3. Install part **a** on the hose.
4. Install part **b** so it fits over the inner plastic hose. Press part **b** on far enough so the plastic hose stops at the inner lip.
5. Push part **c** onto the hose end.
6. Tightened part **a** and part **c** together using wrenches.

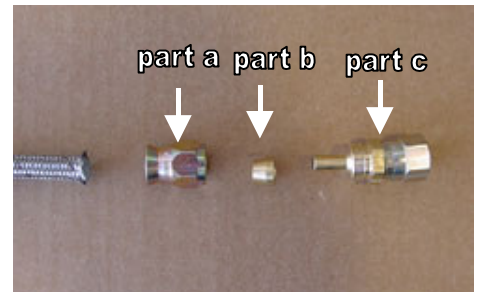
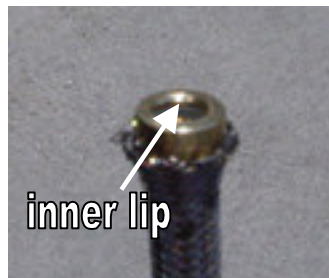

Part IV - Carb Vent to Nitrous Manifold Installation

The nitrous manifold must be able to pressurize the carb float bowl and the carb vent lines must be able to drain if fuel gets trapped in the lines.

Connect the carb vent lines to the nitrous manifold as follows. Splice into the carb vent line with a Tee and run a line from the Tee to the nitrous manifold. Put orificed cup plugs in the bottom of all vent lines – the .025” orifice will allow fuel to drain, but retain pressure to the float bowl.

Refer to the diagrams below for ideas.

A. carb has two vents and one drain

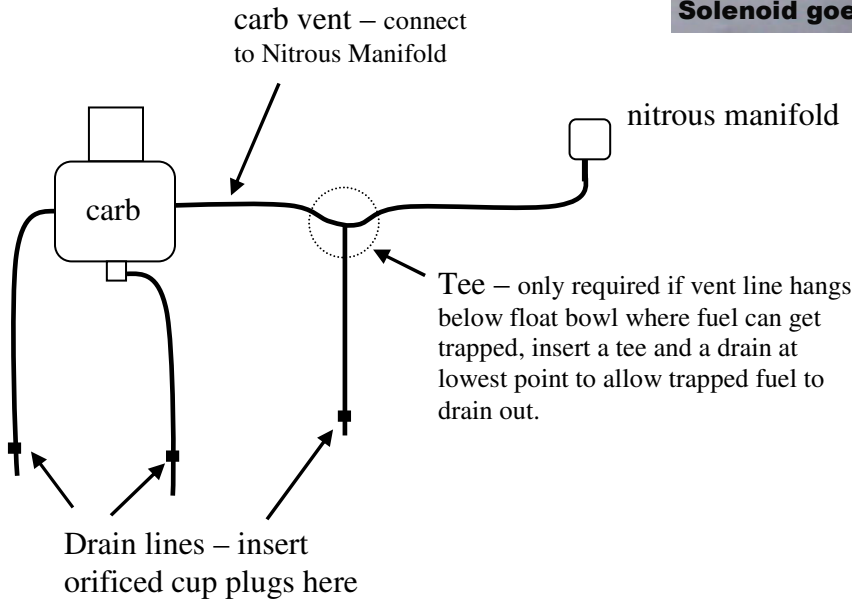

A. carb has four vents and one drain

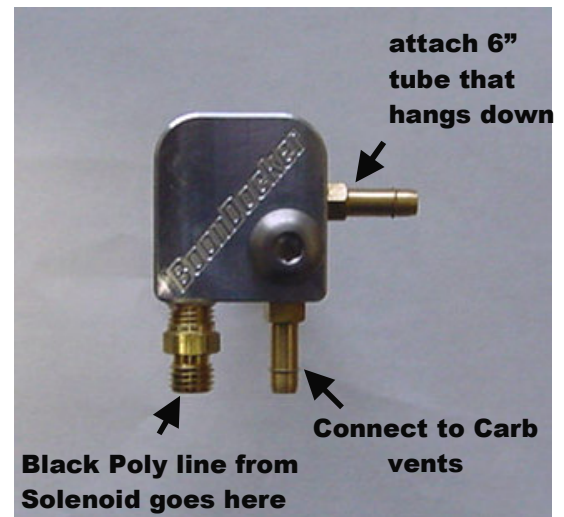
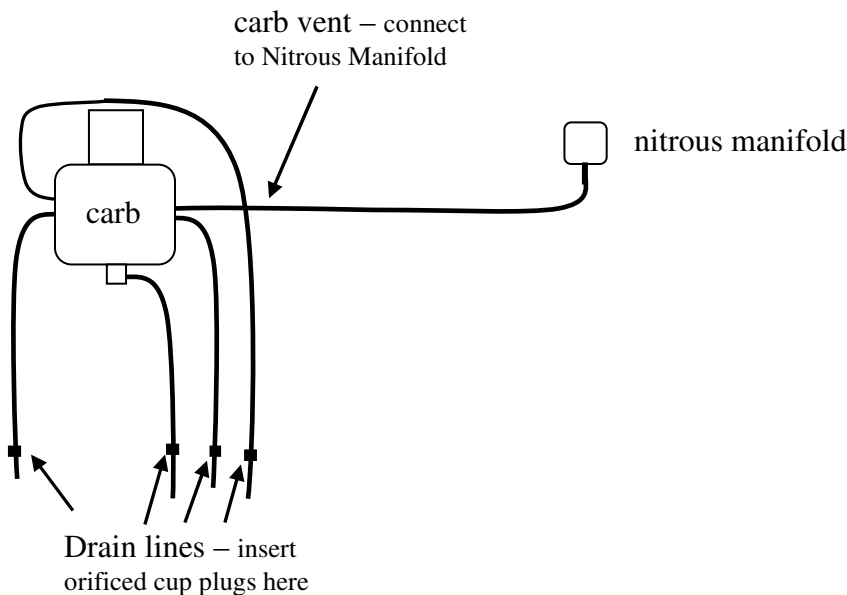

Part IV – Push-Button Installation

The pushbutton switch can be attached to the left handlebar with the clamp provided as shown. The kill button can be moved aside, or moved on the right side of the bar.



Part V – Electrical Installation

The rechargeable battery can be mounted behind the plastic radiator shroud using recloseable fasteners or zip-ties. The battery can also be hidden under the tank as shown in the picture below. Connect the connector plug to the switch and solenoid according to the following diagram.

The batter can be disconnected from the connector and plugged into the charger for easy charging without having to remove the battery from the bike.

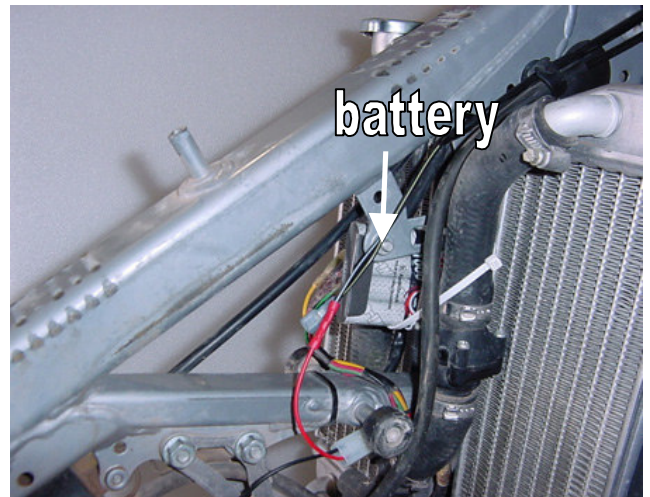
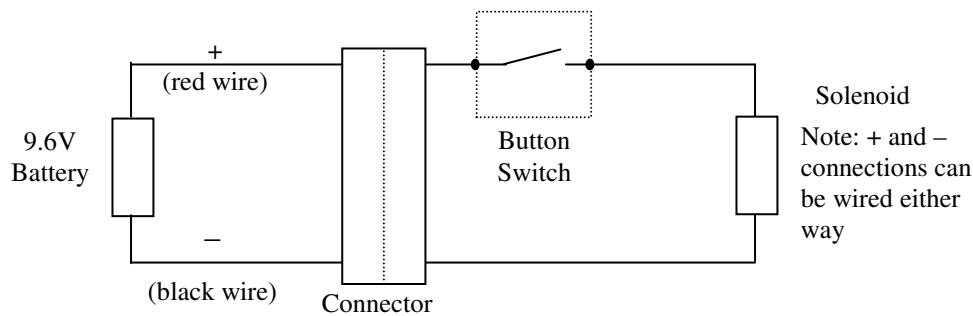

Part VII - Startup and Tuning Procedures

A. Carb Jetting:

If your carburetors were originally vented to atmosphere instead of the airbox, the main jet size may need to be increased. When a large volume of air flows through the airbox, a negative pressure may develop inside depending on how restrictive the airbox is. This negative pressure can cause the engine to run too lean unless the main jet size is increased. Make sure the carb jetting is correct before proceeding with the tuning instructions.

Note: A quick check may be performed as follows:

1. With the nitrous manifold installed, run the bike and note performance.
2. Temporarily disconnect the vent lines from the manifold so the carburetors are vented back to atmosphere.
3. Run the bike again and note if performance improves.
4. If performance has improved, you will need to increase the main jet size. Replace the main jets with a larger size, reconnect the vent line to the nitrous manifold and retest. Continue increasing the main jet size until performance is the same as when the vent was disconnected from the nitrous manifold.

B. Important Notes before using Nitrous:

1. We strongly recommend using high octane fuel (at least 94 for most stock motors, more for modified motors). We have found that race fuel or race fuel concentrate (like Torco Mach Series Fuel Accelerator, or Klotz Htrate) mixed with premium gas can provide the necessary octane.
2. We also recommend using one size colder spark plug (higher number = colder). In some cases decreasing the spark plug gap an additional .003”-.005” (to around .020”) achieves best results.
3. Be sure to use filtered nitrous – always use a filter when filling your bottle!
4. When tuning the system, do not use nitrous for more than 2 seconds at a time. Once the system is properly tuned (see steps below), we recommend not using nitrous for more than 8 seconds at a time. If nitrous is used for longer durations, it is critical that the system be carefully tuned and that no detonation problems are occurring.

C. Startup & Leak Test Procedure

The rider must do the following steps every time the bottle is turned on and before doing the fuel adjustment procedure.

1. With the engine off, open the bottle valve and check for leaks. Shut the bottle valve off. With the valve shut, the hose will still have pressure in it.
2. With pressure in the hose and the bottle valve closed, start the engine. Check to make sure the solenoid does not discharge hose pressure.
3. With the engine running (be ready to shut down engine if necessary), open the bottle valve. Push the nitrous button for about one second or less. In most cases the engine rpm should increase if the nitrous system is functioning properly. Some carburetors may get too much fuel if the nitrous is sprayed at an idle – this will cause the engine to begin to flood and rpms may drop in this case. If the solenoid is not functioning, recheck the electrical connections and voltages and repeat this procedure.

D. Nitrous Manifold Fuel Adjustment Procedure

There is a fuel adjustment screw on the nitrous manifold. This screw adjusts the amount of fuel when nitrous is being used - it does not add fuel off nitrous. The “R” marking stands for “Rich” – turning the adjustment screw **in** (clockwise) will add more fuel when using nitrous.

Warning: Only adjust the fuel mixture screw on the Nitrous Manifold according to the steps below.

The factory setting should provide a starting baseline. Each nitrous manifold requires a different number of turns on the fuel adjustment screw to make a given pressure to the float bowls. We recommend you first count the number of turns in each screw is set at before making adjustments. This will provide a baseline you can return to if necessary. If this setting accidentally gets changed and the initial setting is unknown, turn the screw in (clockwise) all the way and then back out 1.5 turns, then proceed with the steps below.

The steps below should be done with a full nitrous bottle that is at the proper operating temperature (70-90deg F). Make sure the engine is at normal operating temperature. Do not exceed 2 seconds of nitrous use until the fuel adjustment is complete and correct.

This adjustment process should only be performed by an experienced tuner. If you are not an experienced tuner, find someone who is. Remember, safety first!

1. Run the bike in an open area at full throttle and apply nitrous for 1 or 2 seconds. Note engine power and rpms when the button is pushed.
2. Enrichen the mixture by turning the nitrous manifold adjustment screw in (clockwise) 1/2 turn. Run nitrous for 1 or 2 seconds again and note power and rpm difference. If no power loss is noted, repeat step 2 until a loss is noted. A power loss indicates you are rich enough (be sure!) - go to step 3.
3. To find where the mixture starts to become too lean, turn the nitrous manifold adjustment screw out (counterclockwise) 1/2 turn and note power. A power increase should be noted. Turn nitrous manifold adjustment out 1/2 turn and compare to previous run. If no power increase is noted, go to step 4. If power increase is noted, repeat step 3 until no power increase is noted. Use extreme caution - you can go too lean!
4. For the final setting, turn the nitrous manifold adjustment screw back in (clockwise) 1/2 turn.
5. After this adjustment is made, if the engine does not run perfectly smooth when using nitrous, do not use it! If the exhaust note does not sound clean, the cause is likely detonation which can quickly destroy the engine. Either use higher octane fuel, add more ignition retard, reduce the engine's compression, or reduce the amount of nitrous (see next section) before using nitrous again.

Part VIII – Adjusting Amount of Nitrous

It is possible to increase/decrease the amount of nitrous the nitrous manifold sprays by replacing the 3/4" nozzles with more/less orifice holes. In general, each orifice hole that is sprayed is equivalent to a 3-5hp increase.

Read this before you increase nitrous!

Be sure your engine is working good before you decide to increase the amount of nitrous. If you are not getting the power increase you are expecting with the original setup, something is likely wrong. Review the manifold tuning procedure and verify that you can tune the manifold so you know there is too much fuel. From there, if leaning the manifold mixture screw does not produce an increase in power, one of the following problems may exist:

1. Be sure your bottle is full, at the correct temperature (70-90 deg), and positioned correctly so the valve picks up liquid nitrous. The system will not work properly if nitrous vapor is being picked up or if the bottle is too cold.
2. Your engine could be detonating. Detonation can occur if your compression ratio is high, your timing has been advanced, or you are not using good octane fuel. Listen carefully to the motor - if it does not sound clean and you are not too rich, you are likely detonating.
3. A bad power source or faulty electrical connection may cause the nitrous system to malfunction intermittently. Carefully check all connections. If necessary, solder all connections.
4. Dirty nitrous can quickly plug the nitrous filter and obstruct the nitrous delivery. Remove and clean the sintered bronze filter element by blowing compressed air through it backwards. Always fill your bottle from a filtered source.

Installing / Removing Nozzles

1. Remove the nitrous manifold from the airbox/airfilter.
2. Use a 7/32" hex wrench to carefully remove/install a nozzle. Be sure the o-ring is still in place before threading in a new nozzle. Be very careful not to overtighten the plastic nozzle – it needs to be just snug.
3. If you want to increase nitrous delivery, increase the number of nozzle holes by one!
4. Retune the nitrous manifold according to the instructions above. Anytime the orifices are changed, the nitrous manifold pressure will change so retuning is necessary.



Part IX – Warranty, Terms & Conditions

Returned Goods – No merchandise will be accepted without prior approval. A RMA number (Return Merchandise Authorization) provided by Boondocker is required before a return will be accepted. A 20% handling and restocking charge will be applied to returned merchandise. No unauthorized returns will be accepted.

Limited Warranty – Boondocker warrants its product to the original purchaser against workmanship defects for a period of 90 days, commencing from the date of product delivery to the Consumer.

Maximum Liability – The maximum liability of Boondocker in connection with this warranty shall not under any circumstances exceed the price of the product claimed to be defective.